

CB19 CONTROL SYSTEM

USER MANUAL

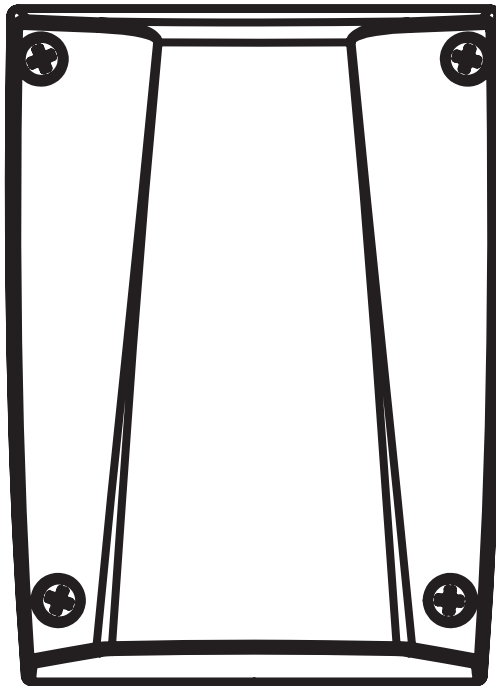

Reuse
Reduce
Recycle



Index

1). Control Box Installation	2
2). Wiring Connection	2
2.1 Motor Connection	3
2.1.1 Motor Only	3
2.1.2 Motor With Limit Switch + LED indicator	3
2.1.3 Motor With Hall Sensor	3
2.2 Wifi Device	4
2.2.1 Back-up Batteries	4
2.3 Accessories	5
2.3.1 Photocells	5
3). Get Started	6
3.1 Step 1: Remote Memorizing	6
3.1.1 Memorizing	6
3.1.2 Remote learning without Control board	7
3.1.3 Deleting memory of single command	7
3.1.4 Deleting all memory of all remotes	7
3.2 Step 2: System Learning	8
4). Gate Operation Logic	9
5). Safety For Gate Operation	9
6). LED Indication	9
6.1 LED Lighting	9
6.2 Function of the LED display	9
7). Parameter Modification	10
7.1 Parameter Learning	10
7.2 Parameter	10
7.3 Photocell Logic	12
8) .Trouble Shooting	13
9). Technical Specification	14

1). Control Box Installation

1. Decide the installation position of control box first, it is suggested to be installed near the gate and should be protected from possible damage. Be aware of the motor cable length before deciding the installation position.
2. Remove the cover by unscrewing the four screws on the cover. See Figure A.
3. Use a screwdriver to puncture the holes beneath the bottom of the control box. See Figure B.
4. Secure it on the wall Figure C.

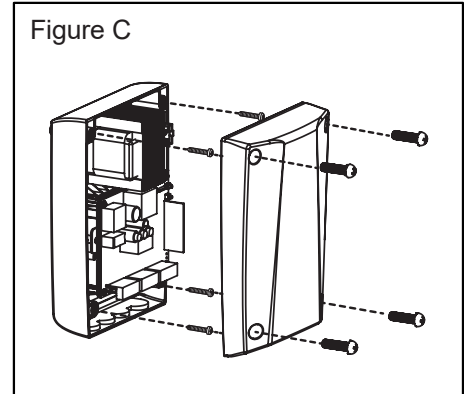
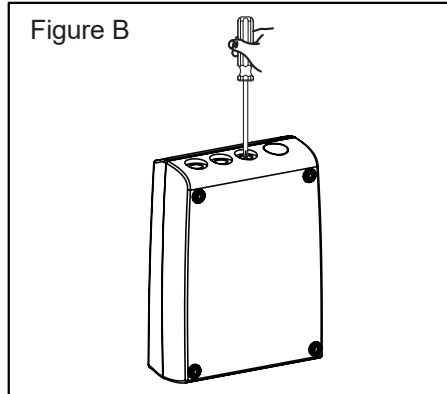
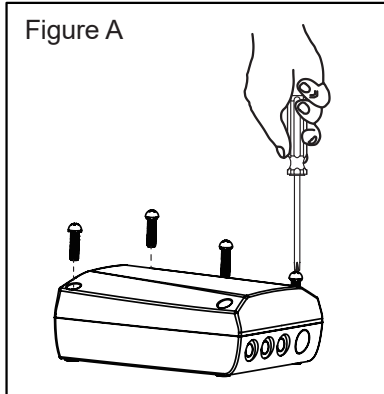

2). Wiring Connection

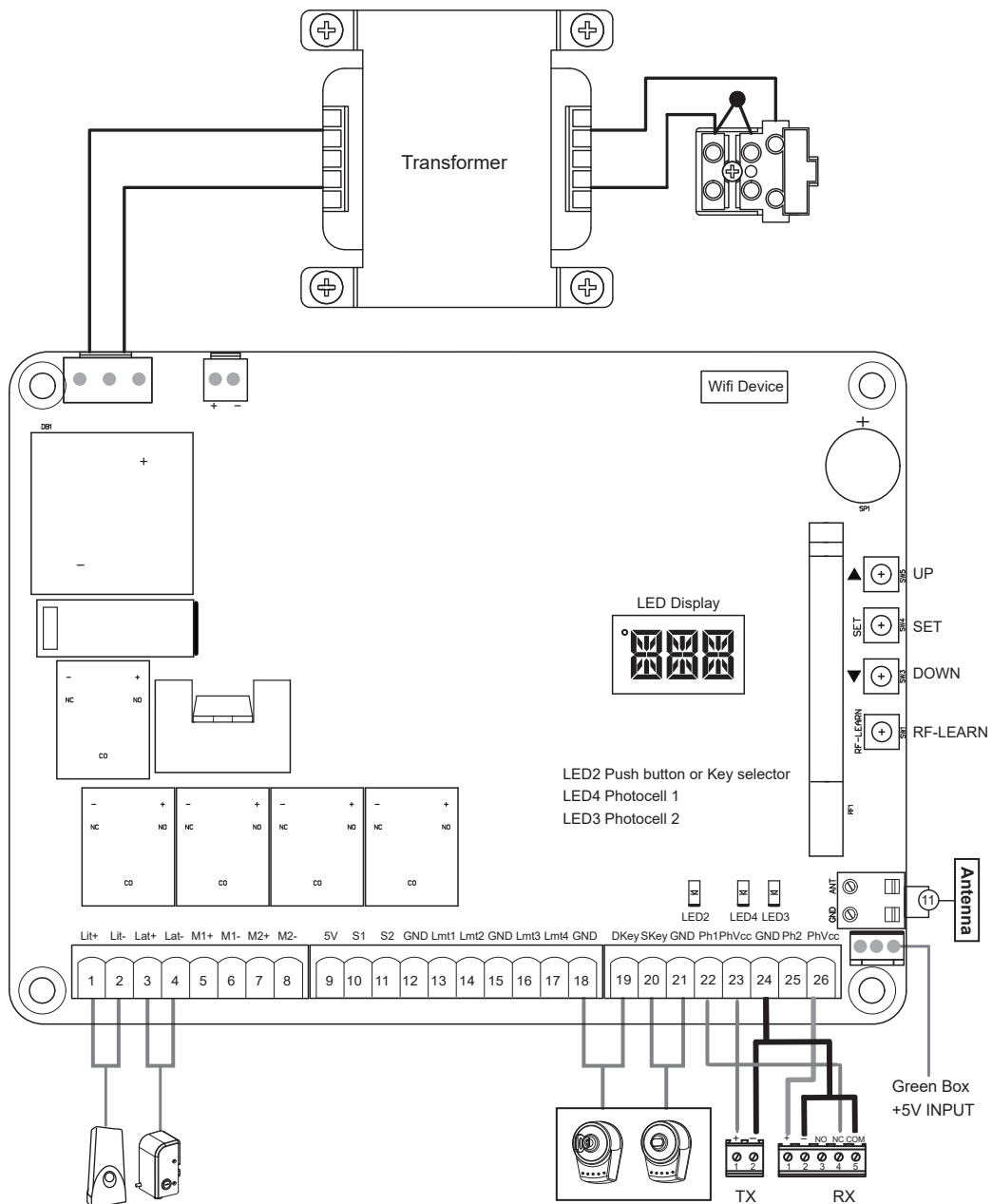

2.1 Motor Connection

2.1.1 Motor Only

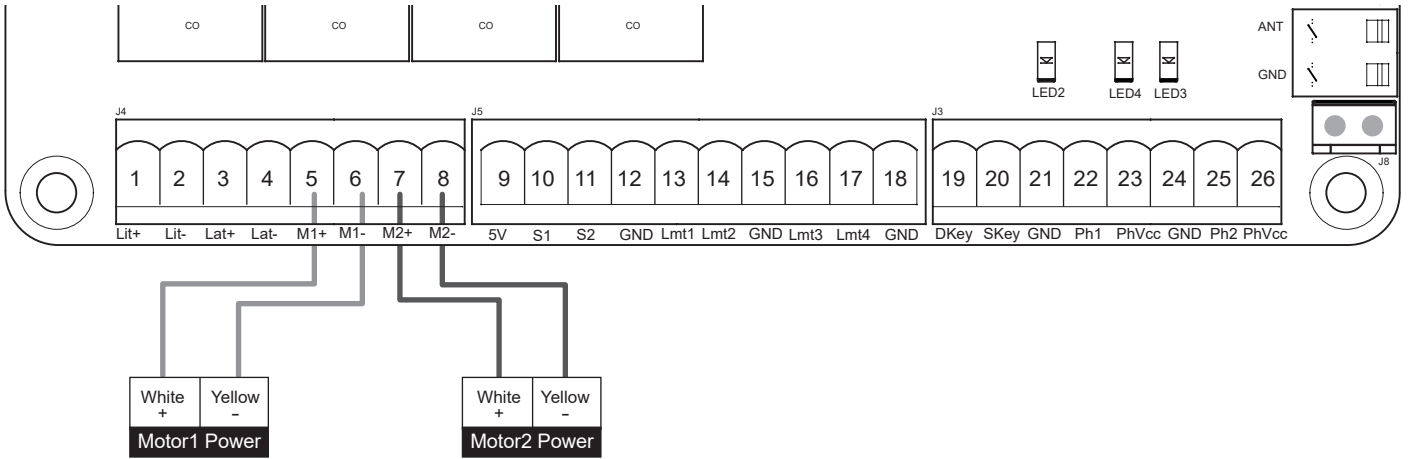

2.1.2 Motor With Limit Switch + LED indicator

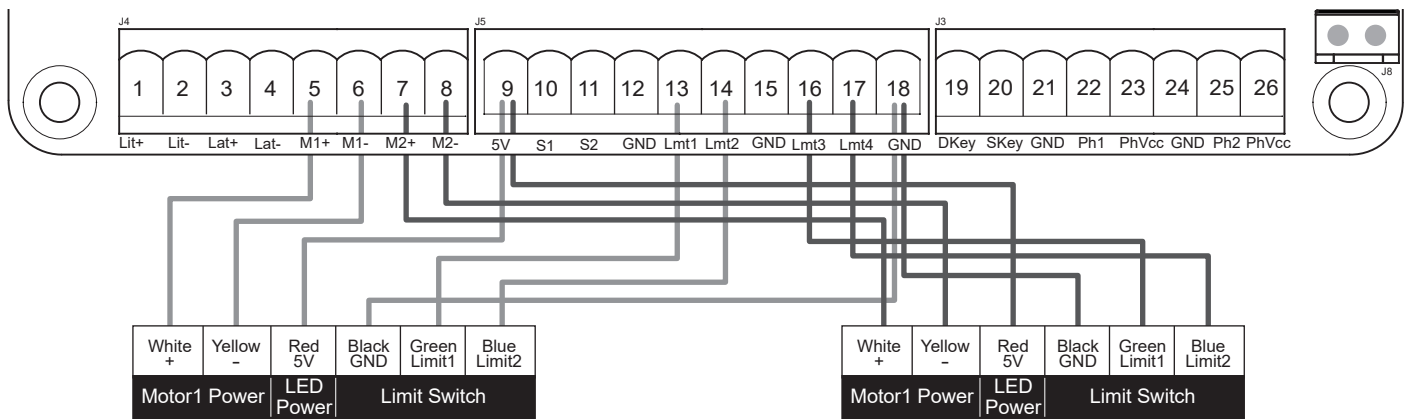

2.1.3 Motor With Hall Sensor

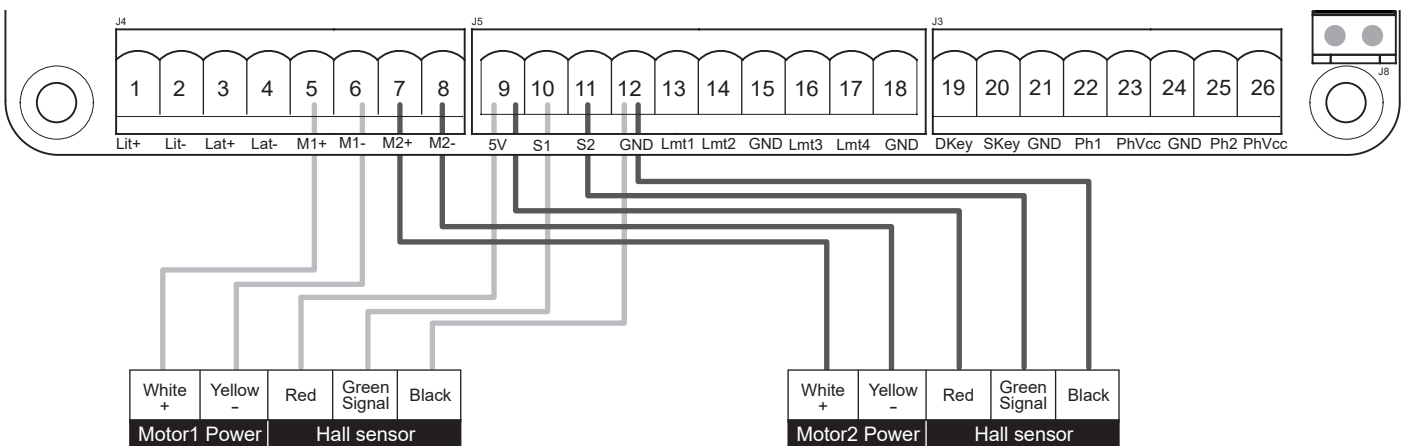

2.2 Wifi Device

Functions of Buttons and Terminals

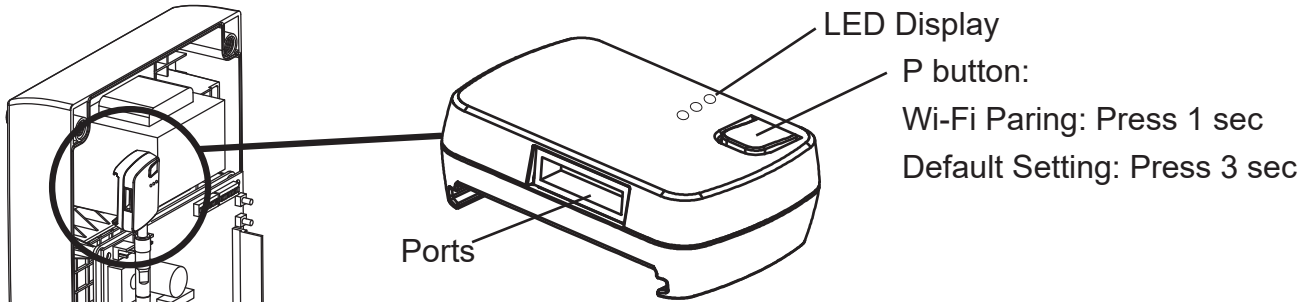

• LED description:

Blue: LED will be flashing during WIFI pairing, and be ON when completed.

Green: LED will be flashing if WB-001 receives signal from APP.

If your home WIFI disconnects, the green light will continuously flash, and it will be off until WIFI is connected again.

Red: System failure or wrong PIN.

2.2.1 Back-up Batteries

Battery Power: The battery white connector must be fitted the correct way round (positive red to +positive) or you will short circuit the control board. There are 2 x 12v batteries fitted under the control board. They are connected together in series to make 24vDC via a black cable with a yellow fuse with positive of one battery to negative of second battery. The remaining positive and negative terminals go to the control board as per the photo above

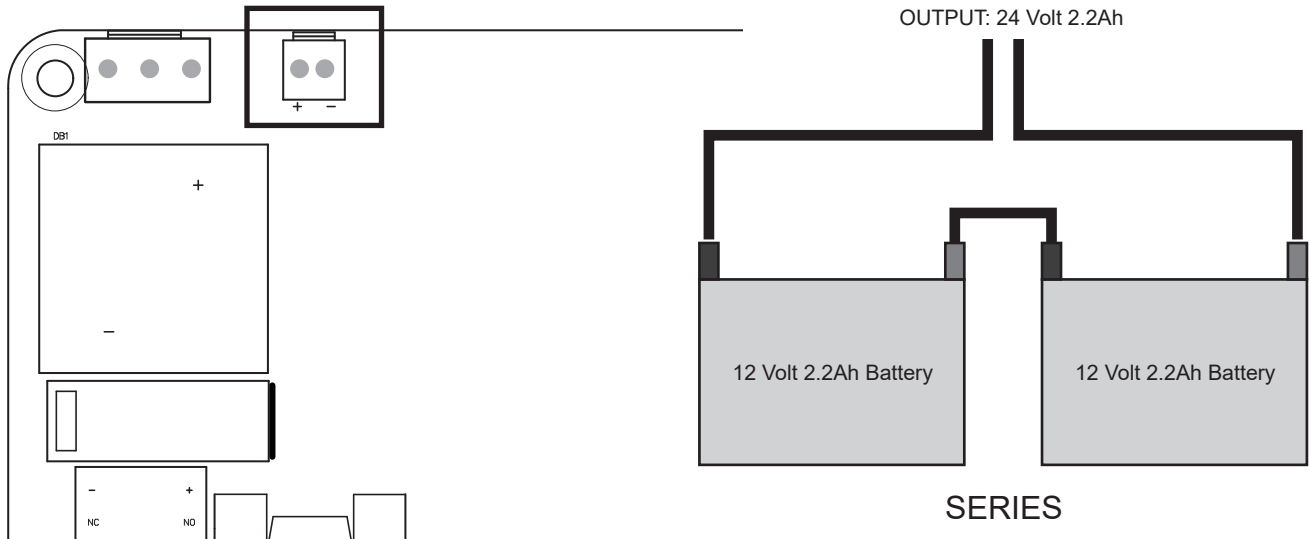

2.3 Accessories

2.3.1 Photocells

The safety photocells are security devices for control automatic gates. Consist of one transmitter and one receiver based in waterproof covers; it is triggered while breaking the path of the beams.

SPECIFICATION:

Detection Method	Through Beam
Sensing Range	MAX~15m
Input Voltage	AC/DC 12~24V
Contact Current	TX: 30mA Max , RX: 25 mA Max
Response Time	<100mS
Emitting Element	Infrared LED/ Wave Length : 940nm
Operation Indicator	RX : Red LED On (beam broken) / Off (beam aligned) TX : Red LED On
Dimensions	63*63*30 mm
Output Method	Relay Output
Current Consumption	Beam aligned : RX<25ma\TX<30ma Beam broken : RX <10ma\TX <30ma
Connection Method	Terminal Block
Housing Material	ABS / PC
Water Proof	IP44
Safety Standard	CE

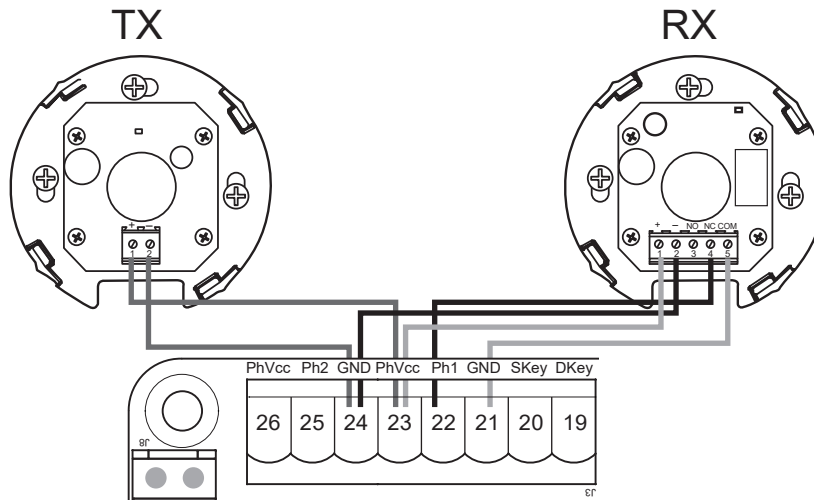
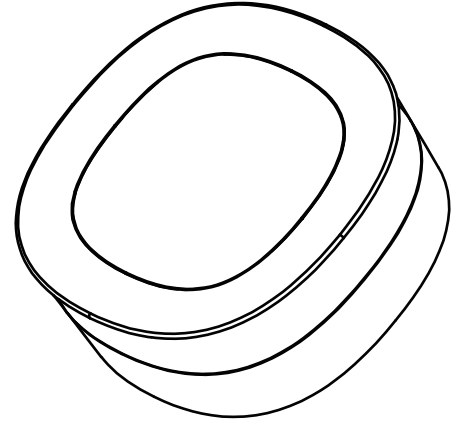

INSTALLATION:

1. Open the cover and connect wires.
2. Mounted the receiver and transmitter on the proper position.
3. Ensure there are no obstacles between receiver and transmitter.
For optimal efficiency, the receiver and transmitter should be properly aligned.
4. Power-up the photocells and make sure the LED light on receiver and transmitter are ON.

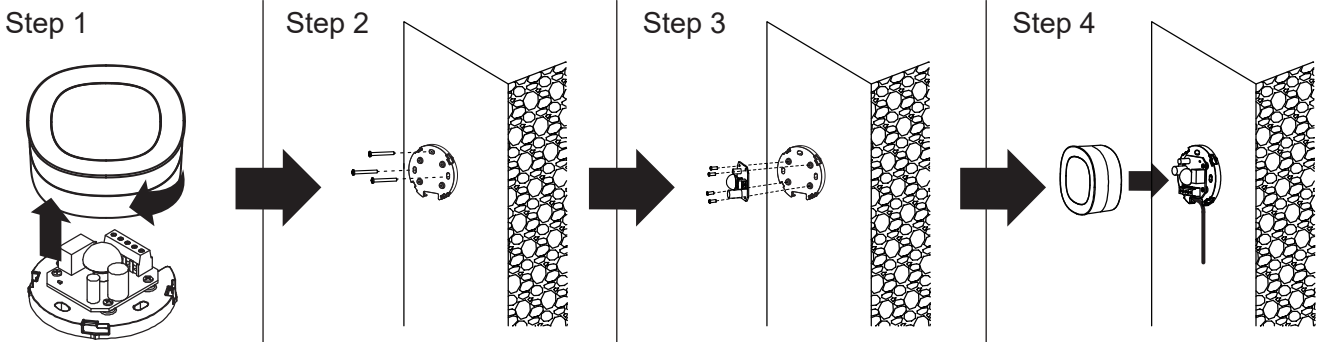

3). Get Started

Note:

(A) Transmitter memorizing must be done first before system learning.

(B) CHECKING THE Gate MOVEMENTS

- 1) Release the gearmotor with the release key and move the gate to the middle so that it is free to move in both opening and closing directions; then lock the gearmotor.
- 2) Perform the gate opening and closing several times and make sure the gates touches the limit switch at least 2~3 cm before the mechanical stop.

3.1 Step 1: Remote Memorizing

3.1.1 Memorizing

1. Press button RF-Learn on the control board (Figure 1) as many times as the number corresponding to the desired command, according to the following table, Within 10s, press the desired button on the remote that you want it to be memorized (figure 1)

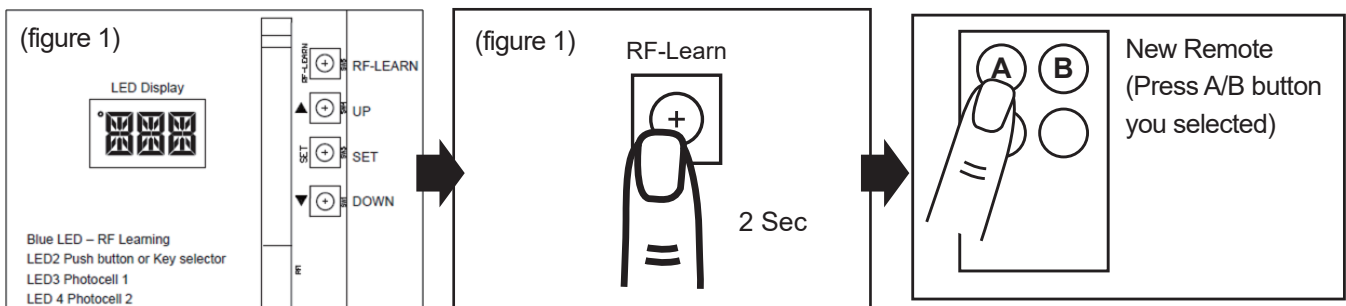

Times for pressing RF-Learn	Command	Message code
1 times	Open/Stop/Close circle	LEDdisplay "OSC"
2 times	Pedestrian mode	LEDdisplay 'PED'

2. Make sure that the LED display shows the "OSC" or "PED" three times quickly. The code is corresponding to the selected command. (figure 2)

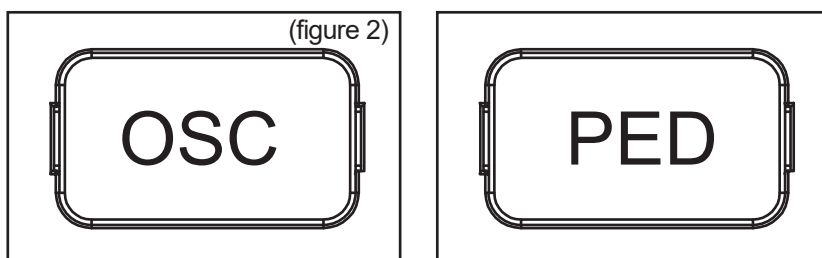

3. Repeat step 1 & 2 within 10s, if there are other remotes to be memorized for the same type of command. No action within 10s, the memorization stage will terminate automatically.

3.1.2 Remote learning without Control board:

1. Press the button on the NEW radio transmitter and hold it down for at least 5s, then release it.
2. Press the button on the OLD radio transmitter 3 times. (Tip: Don't press too fast; make sure you see the blue flash when pressing the button each time.)
3. Press the button on the NEW radio transmitter once.
4. Done, at this point the NEW radio transmitter will copy the same command of the OLD one.

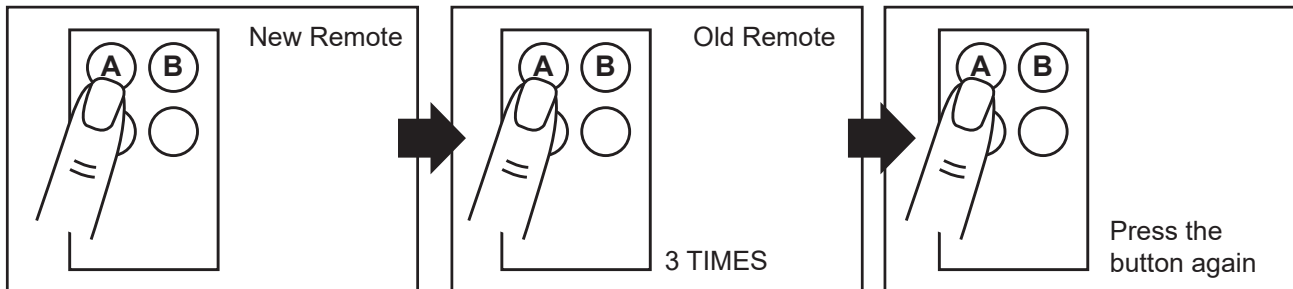

3.1.3 Deleting memory of single command:

Single deletion stage is needed for each memorized button.

1. Press and hold down RF-LEARN button (Figure 3) on the control board for 5 seconds.
2. Wait until the LED display shows "DKY", then, within three seconds:
3. Press the button of the remote to be deleted. If the remote has been deleted, the LED display will flash quickly five times.
4. Repeat above steps if more button to be deleted.



3.1.4 Deleting all memory of all remotes:

With this operation all the memorized transmitters will be deleted.

1. Press and hold down RF-LEARN button (Figure 4) on the control board for 10 seconds.
2. Wait until the LED display shows "DAL". (When you see DKY, keep pressing the RF-Learn till it shows DAL). All memory is deleted.

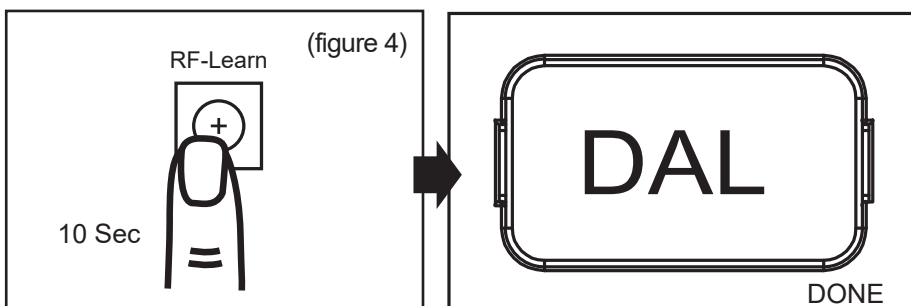

3.2 Step 2: System Learning

Step1:

Press and Hold the Press SET button for 3s, When LED shows "LEA" then release SET, then the motor runs the system learning procedure automatically, once learning completed shows "D-G" or "S-G"
(No remote required)

Note: Please check the parameter setting of "FI"(Dual/Single) before going into system learning.

Restore system default setting

Press and Hold the UP + SET + DOWN button for 5s and panel restores back to default setting

Note:

1. LED Shows "D-G" tells the system learning has be completed for Dual Gate installation
2. LED Shows "S-G" tells the system learning has be completed for Single Gate installation



A. Dual Gate:

- (1) Slave Gate Close → (2) Master Gate Close → (3) Master Gate Open →
(4) Slave Gate Open → (5) Slave Gate Close → (6) Master Gate Close

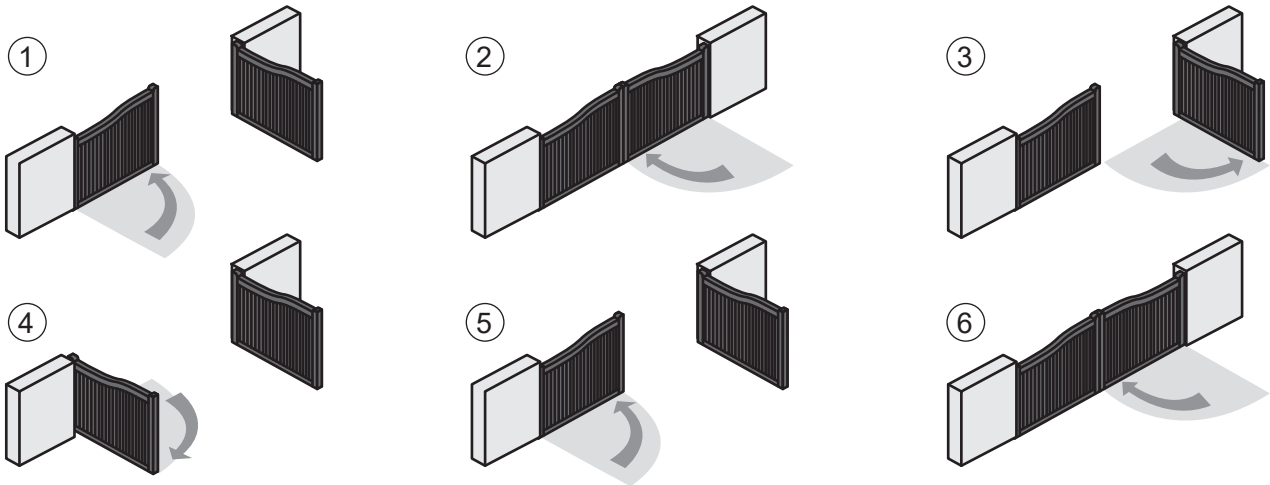

B. Single Mode :

- (1) Master Gate Close → (2) Master Gate Open → (3) Master Gate Close

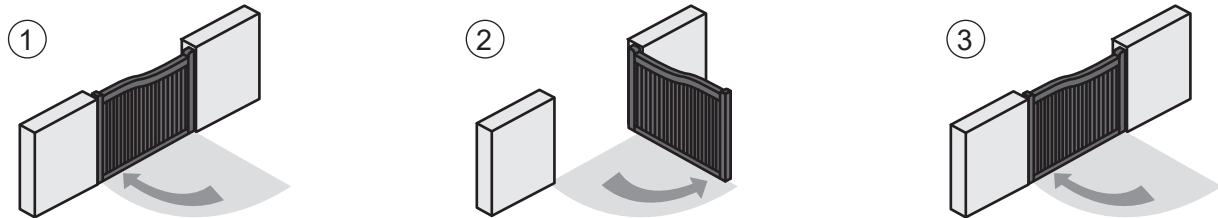

For Single Gate installation, please make sure the motor cable connect to M1+/M1-, and parameter to set function FI-1 to single gate, and also set FB-0 pedestrian mode to be function off, and once the system learning is completed, the LED will show S-G

4). Gate Operation Logic

- (A) In gate-opening phase: The gates stop if the transmitter/push button/key selector is activated, and close when the transmitter/push button/key selector is reactivated.
- (B) In gate-closing phase: The gates stop if the transmitter/push button/key selector is activated, and open when the transmitter/push button/key selector is reactivated.

5). Safety For Gate Operation

- In gate-opening phase: For safety purpose, the gates stop if encountering obstacles.
- In gate-closing phase: For safety purpose, the gates reverse for 2 sec if encountering obstacles.

6). LED Indication

6.1 LED Lighting

Blue LED System Learning: Blue LED in receiver board blinks two times when learning is completed.

LED2 RF : Key selector, or the push button is activated, LED2 will be on.

LED4 Ph1 : LED4 will be on when Ph1 are triggered.

LED3 Ph2 : LED3 will be on when Ph2 are triggered.

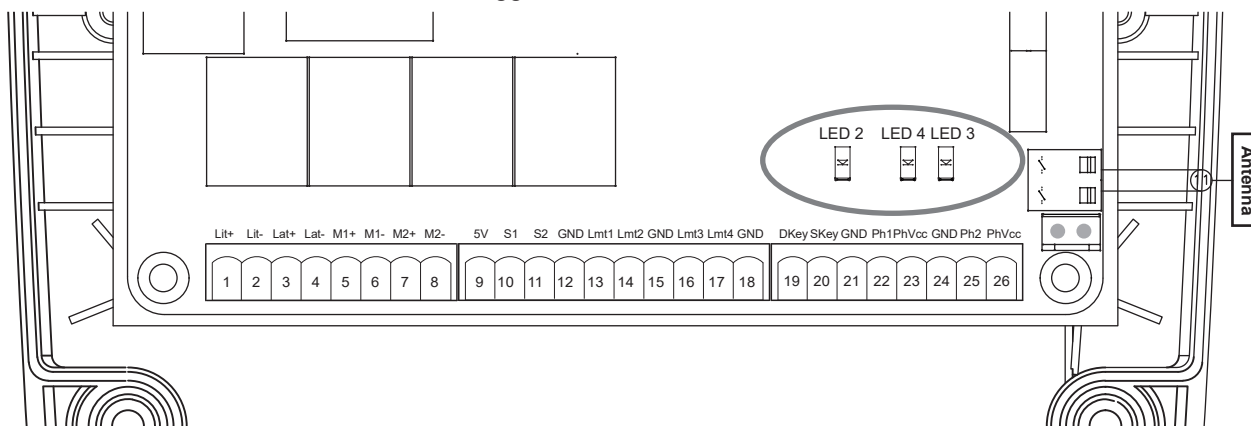

6.2 Function of the LED display

LED Display	Programmable Functions	LED Display	Programmable Functions
	[LEA] means motor into the system learning mode, do not interrupt during this procedure		When the gate is stopped, the LED Display show 'STP' until next command has been made, after 10s no further movement, the LED turns to OFF
	[D-G] means motor completed the learning procedure for dual gate installation		When the gate is closing, the LED Display show 'CLS' for 2s and then change to Amp current indication
	[S-G] means motor completed the learning procedure for single gate installation		LED display shows "S01" means the panel did not detected the M1+/M1 and M2+/M2 both been connected before the system learning procedure, check for 2 motors' wire connection, for dual gate system
	The memory of the system is all deleted/cleaned by press and hold the UP + SET+ DOWN button together for 5s and the panel will be back to default settings		LED display shows "S02" means the panel did not detected the M1+/M1 but detected M2+/M2 been connected, notice the installer to check the motor wire connection, if this is single gate system, motor wire should connect to M1+/M1 not on M2+/M2
	When the gate is opening, the LED Display show 'OPN' for 2s and then change to Amp current indication		LED display show "S03" means same button on the remote has been identified for more than 2 functions

7). Parameter Modification

7.1 Parameter Learning

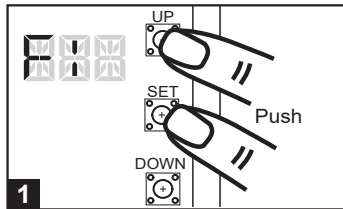

1 Press "UP+SET" for 3 seconds to get into the program setting display from F1.

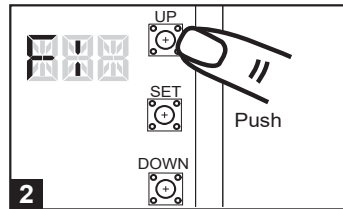

2 Press "UP" or "DOWN" to change setting item from F1 to FJ .

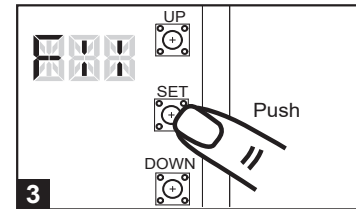

3 Press "SET" button again to get into the sub-settings

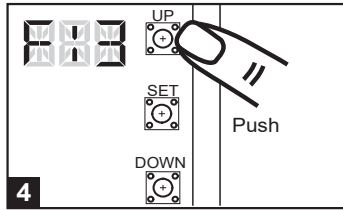

4 Press "UP" or "DOWN" to change Push from F1-1 to F1-3.

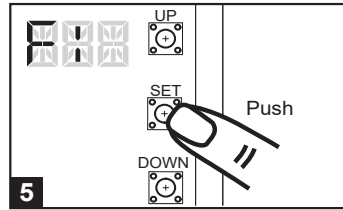

5 Press "SET" button again to confirm.

7.2 Parameter

LED Display	Definition	Parameter	Table	Description
F1	Motor Type	F1-1	Overcurrent	1. The factory setting is "F1-1"
		F1-2	Limit Switch	
		F1-3	Hall Sensor	
F2	Overcurrent for Gate Opening	F2-1	2A	1. The factory setting is "F2-2".
		F2-2	3A	
		F2-3	4A	
		F2-4	5A	
F3	Overcurrent for Gate Closing	F3-1	2A	1. The factory setting is "F3-2".
		F3-2	3A	
		F3-3	4A	
		F3-4	5A	
F4	Motor Speed for Opening	F4-1	40%	1. The factory setting is "F4-3".
		F4-2	50%	
		F4-3	75%	
		F4-4	100%	
F5	Motor Speed for Closing	F5-1	40%	1. The factory setting is "F5-3".
		F5-2	50%	
		F5-3	75%	
		F5-4	100%	
F6	Deceleration Speed	F6-1	40%	1. The factory setting is "F6-2".
		F6-2	50%	
		F6-3	60%	
		F6-4	70%	
F7	Time Gap b/w Two Gates (Opening)	F7-0	0 sec	1. The factory setting is "F7-1".
		F7-1	2 sec	
		F7-2	5 sec	
		F7-3	10 sec	
		F7-4	15 sec	
		F7-5	20 sec	
		F7-6	25 sec	
		F7-7	35 sec	
		F7-8	45 sec	
F7-9	55 sec			

F8	Time Gap b/w Two Gates (Closing)	F8-0 F8-1 F8-2 F8-3 F8-4 F8-5 F8-6 F8-7 F8-8 F8-9	0 sec 2 sec 5 sec 10 sec 15 sec 20 sec 25 sec 35 sec 45 sec 55 sec	1. The factory setting is "F8-1".
F9	Auto-closing	F9-0 F9-1 F9-2 F9-3 F9-4 F9-5 F9-6 F9-7 F9-8	Function OFF 3 sec 10 sec 20 sec 40 sec 60 sec 120 sec 180 sec 300 sec	1. Auto-close mode activates when the gates move to the end position or stopped manually. If the transmitter, push button, or the key selector is activated before the auto-close counting, the gate will close immediately. 2. The factory setting is "F9-0".
FA	Safety Device Function Mode	FA-1 FA-2 FA-3 FA-4	Mode 1 Mode 2 Mode 3 Mode 4	1. Please see 7.3 photocell adjustment for photocell logic 2. The factory setting is "FA-1".
FB	Pedestrian Mode	FB-0 FB-1	Function OFF Function ON	1. The factory setting is "FB-1".
FC	Flashing Light	FC-0 FC-1	Function OFF Function ON	1. When function FC-1, the light will flash for 3 seconds before the gate operates. If set OFF, the flash light will operate with motor at the same time. 2. The factory setting is "FC-0".
FD	Photocell Activation	FD-0 FD-1	Function OFF Function ON	1. The factory setting is "FD-0".
FE	Photocell 2 Activation	FE-0 FE-1	Function OFF Function ON	1. The factory setting is "FE-0".
FF	Alarm Buzzer	FF-0 FF-1	Function OFF Function ON	1. The factory setting is "FF-0".
FG	Electric Latch Mode	FG-0 FG-1	Standard Gate Opening Release Gate Tension before Opening (Gate Reversing for 0.25s)	1. If the function is FG-1, the motor will be reversed for 0.25 sec. to release the tension. 2. The factory setting is "FG-1".
FH	LED Direction	FH-0 FH-1	When Terminal Block is at Top When Terminal Block is at Bottom	1. The factory setting is "FH-1". The UP(▲) and Down(▼) buttons will switch according to the parameter setting. When FH-0, button SW3 stands for ▲(UP) , and button SW5 stands for ▼(DOWN). When FH-1, button SW5 stands for ▲(UP) , and button SW3 stands for ▼(DOWN)
FI	Dual / Single Gate	FI-1 FI-2	Single Gate Dual Gate	1. The factory setting is "FI-2".
FJ	Over Current Reverses Time when Close	FJ-0 FJ-1 FJ-2 FJ-3 FJ-4 FJ-5 FJ-6	Function OFF 0.1 sec 0.2 sec 0.3 sec 0.4 sec 0.5 sec 0.6 sec	1. The factory setting is "FJ-0"

Note(F1-3 over-current setting in Hall sensor mode):

Only in "F1-3" Hall sensor mode, the PCB will record all the current value in learning mode. Please adjust over current value by setting F3 function after learning mode.

The recorded current values will increase according to the value shown on LED display as over current value.

The value can be adjusted by pressing button UP and DOWN. The maximum value is 50(5.0A) and the minimum value is 05(0.5A).
LED display example:



Indicate 1.0 ampere: all of the recorded values will increase 1 ampere as over current value.



Indicate 2.8 ampere: all of the recorded values will increase 2.8 ampere as over current value.



Indicate 0.6 ampere: all of the recorded values will increase 0.6 ampere as over current value.

7.3 Photocell Logic

FA-1 Photocell OPEN/CLOSE (Standard set up)

Position of Gate	When safety devices are activated	
Type of Safety Device	PH1 Photocell-CLOSE	PH2 Photocell-OPEN
FULLY CLOSED	No effect	Open not allowed
FULLY OPENED	Reload automatic closing time	No effect
STOP DURING MOVING	Reload automatic closing time	Open not allowed
CLOSING	Open	No effect
OPENING	No effect	Close

FA-2 Safety Edge

Position of Gate	When safety devices are activated	
Type of Safety Device	PH1 Photocell-CLOSE	PH2 Safety Edge
FULLY CLOSED	No effect	Open not allowed
FULLY OPENED	Reload automatic closing time	
STOP DURING MOVING	Reload automatic closing time	OPEN/CLOSE not allowed
CLOSING	Open	Reverse to open for 2 seconds
OPENING	No effect	Reverse to close for 2 seconds

FA-3 Open Only Device (Vehicle detector)

Position of Gate	When safety devices are activated	
Type of Safety Device	PH1 Photocell-CLOSE	PH2 Opening Device
FULLY CLOSED	No effect	Open
FULLY OPENED	Reload automatic closing time	
STOP DURING MOVING	Reload automatic closing time	Open
CLOSING	Open	Open
OPENING	No effect	No effect

FA-4 Double photocell set up

Position of Gate	When safety devices are activated	
Type of Safety Device	PH1 Photocell-CLOSE	PH2 Photocell-OPEN/CLOSE
FULLY CLOSED	No effect	Open not allowed
FULLY OPENED	Open for 2 seconds, when auto closing is ON	No effect
STOP DURING MOVING	Close not allowed	Open not allowed
CLOSING	Open	No effect
OPENING	No effect	Stop

8) .Trouble Shooting

Issue:	Solution:	Parts to look at:
No power on the board.	<ul style="list-style-type: none"> - Power to the transformer is on and the connector block from the AC power lead to the transformer and to the control board is wired correctly. - At the control board check the transformer white connector blocks are correctly plugged into board and the battery connector if equipped. - Check fuses are both working. * 15amp for stand-alone transformer. - Check there is 24vac into and out of the Control box fuse. - The batteries are connected to the control board and read higher than 24vdc if equipped. - Try removing optional extras such as beams and probes to see if they are draining the power. And reset the control panel to default and testing the motor operation 	<ul style="list-style-type: none"> - Fuse - Transformer power - Loose wires - Incorrect wire contact at connector blocks - Short circuit in wiring between transformer and board - Battery
A single arm activation isn't working.	<ul style="list-style-type: none"> - Check function setting is set correctly for single arm. FI-1 single gate mode. FB-1 Pedestrian mode to be ON. Using button B on the remote to operate the single gate. - Make sure the arm is connected to motor 1 and not motor 2. - Your remote is programmed in. - You have done a systems learn. - There is adequate power going to the board. 	<ul style="list-style-type: none"> - Motor connection - Function setting for single mode
Remotes or wireless keypad not working.	<p>Re-program remotes by pressing the RF-Learn button on the control board.</p> <ul style="list-style-type: none"> - You can program in several remotes or devices at a time however all signals need to be sent before the blue light goes off again. - Push the button fairly solid and hold it in for a whole second. The blue light should flicker. - If the blue light is on continuously without pressing the RF learn button it means the receiver is faulty and needs to be replaced. - The blue light will still flash when a remote that has not been programmed in is used. It will however not activate. - Reset the keypad. Do this by flicking off the front cover with a small screw driver. Undo the 2 nuts, turn over and repeat until left with the control board on the casing. Undo the 3 screws in the corner. Turn over the circuit board and there is a button there. Hold it until you hear a beep. Try keypad again and reassemble. 	<ul style="list-style-type: none"> - RF Learn button on control board
Lights on the board but arm(s) not moving.	<ul style="list-style-type: none"> - Check the LED3 and LED4 on the board are off, which is located on the button right of the board if it is on check the photocell connection and function - Check that the battery is 24V+. - Make sure your connections aren't loose. - The power input is feeding in 24V+. - The gate is free from any obstructions. - The arm is locked into place (A good way to test this is if you can move the gate freely, then it won't work via the motors). - Try depowering and repowering the board. - If it still keeps glowing please call or email us. Receiver may need replacement. 	<ul style="list-style-type: none"> - The gate - Power sources - Arm wires.
Gates remain open after systems learn/one arm stays open and the other one closed.	<ul style="list-style-type: none"> - Ensure you have matched the + and - of each ram to the equivalent + and – motor symbols on the board. - Change the polarity connection of the positive(+) with the negative(-) of the motor if the gate both stay open instead of close after the system learning - Clear any obstructions to the gates. - Make sure that the arms are going no further than 100 degrees. - The function setting should be set for a double swing and not a single. - Check the LED display during the system learning showing the motor current, once the reading is too high check the installation or the gate condition . - Ensure the motors are locked in. - Increase the power amp settings by function setting F2 for open and F3 for close direction (mentioned above). 	
Gates not fully opening or closing	<ul style="list-style-type: none"> - Ensure there is nothing obstructing the gate or the arms. - If the gate is a bigger or heavier gate change the power settings using the F2 for open and F3 for close direction. You should not have to use the maximum power setting. This is intended for a 500kg double swing gate (or 250kg single). - Re-do the systems learn. 	
One gate opens part of the way/not at all.	<ul style="list-style-type: none"> - Make sure you are pressing the top left hand button. The other buttons do have their individual functions. - Check the FB function for pedestrian mode, set to FB-0 if you require the single gate to be fully open instead of partial open - Both arms are wired onto the control board correctly. They should be identical. I.E. black, red. Black, red. 	
Remote/ keypad range is less than 20M	<ul style="list-style-type: none"> - Make sure the antenna is attached and screwed in on the control board. - Make sure there is nothing obstructing the antenna such as the power cable or motor cables. 	

9). Technical Specification

Main power supply	230Vac/110Vac, 50Hz/60Hz
Back-up battery	2pcs of batteries for emergency operation, 2.2A each
Receiver board	433.92MHz; 200 transmitters memory
Installation	Wall mounted vertically
Operating Temperature	-20°C~+50°C
Dimension	275mm * 195mm * 102mm